

# **APOLLO**

## **SPRAYERS MANUAL**

**BAMBI AIR COMPRESSORS LTD**

**152 Thimble Mill Lane  
Heartlands  
Birmingham  
B7 5HT  
United Kingdom  
Tel: 0121 322 2299  
Fax: 0121 322 2297**

**Email: [sales@bambi-air.co.uk](mailto:sales@bambi-air.co.uk)  
[www. bambi-air.co.uk](http://www.bambi-air.co.uk)**

**ISSUE 1**



## INTRODUCTION

Your Apollo Sprayer is a precision engineered high quality product that will give years of reliable service and excellent results, provided you follow the instructions and advice given in this booklet.

**See the back page for technical support.**

## CONTENTS

	<b>Page</b>
<b>Safety Notes</b>	<b>2</b>
<b>Using the Hobby Plus Spray Gun</b>	<b>3 to 4</b>
<b>Using the ANB300 Spray Gun</b>	<b>5 to 8</b>
<b>Paint Viscosity</b>	<b>9</b>
<b>Basic Spraying Techniques</b>	<b>9 to 10</b>
<b>Filter Removal / Replacement</b>	<b>11</b>
<b>Fault Finding / Preventative Maintenance</b>	<b>12</b>

## SETTING UP

The Apollo spray system consists of three main items: the turbine unit, the spray gun and the hose.

Your first step is to connect the hose to the spray gun and the turbine. Some models have a push on fitting others have a quick connect fitting. Whichever hose you have, do not use excessive force, see page 6.

When the turbine is running the Hobby Plus spray gun will exhaust air all the time. The ANB300 spray gun will only exhaust air when you pull the trigger.

# IMPORTANT

Read these safety instructions in conjunction with your Apollo manual

## FOREWORD

Parts and service advice are available from your Apollo distributor.

It is important to quote the MODEL TYPE and SERIAL NUMBER in all communications.

The substitution of parts not manufactured or approved by Bambi Air Compressors Ltd, can impair the performance, service life and create potential mechanical or personal hazards as well as invalidating your warranty.

Operation and routine service are covered in this manual. Bambi Air Compressors Ltd reserve the right to modify the contents of this manual without prior notice and the information given is in no way binding to the company.

## SAFETY PRECAUTIONS

All spray painting can be a hazard to health and safety if not handled correctly.

- ! Never direct paint or any other fluids at any part of the human body.
- ! Do not dismantle the spray gun or disconnect hoses until the turbine is switched off.
- ! Site the turbine in a well ventilated area and position away from the user to ensure no solvent vapours can be drawn into the turbine. Particular attention must be paid when working indoors to ensure a sufficient flow of air will extract all solvent vapours. When working outside take into account the wind direction.
- ! Whenever spraying you must wear an appropriate face mask or respiratory equipment.
- ! Always follow the material manufacturers application guidelines which can normally be found on the original container.
- ! During operation the turbine outlet and hose connection will become quite hot to the touch, this is a normal operating condition, but care must be taken to prevent burns (when the turbine has been switched off allow sufficient time for the fitting to cool before attempting removal).

## ELECTRICAL CONNECTIONS

### ! IMPORTANT !

Do not attempt any work on the turbine until it has been isolated from the mains electricity supply.

Turbines are supplied with a length of mains cable wires coded to IEC227 and IEC245.

i.e. **BLUE - NEUTRAL**

**BROWN - LIVE**

**YELLOW/GREEN STRIPE - EARTH**

# HOBBY PLUS SPRAY GUN

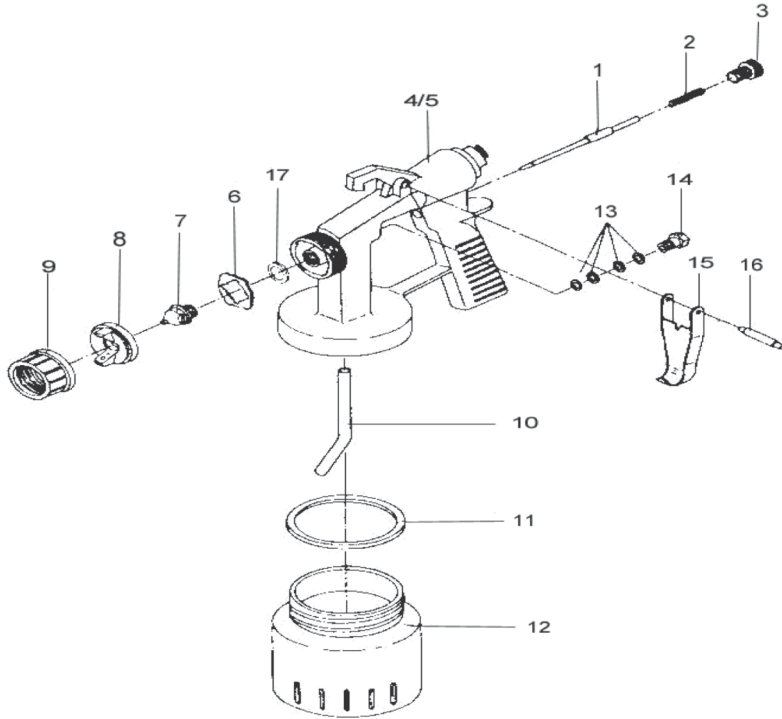

Position No	Description	Part No
1	Needle	GP123
2	Needle Spring	GP124
3	Paint Flow Adjusting Screw	GP125
4	Gun Body - Spraymate	GP126
5	Gun Body - Spraymaster	GP127
6	Cruciform	GP128
7	Spray Jet	GP129
8	Aircap	GP130
9	Aircap Locking Ring	GP131
10	Paint Tube	GP132
11	Cup Top Seal	GP133
12	Paint Cup	GP134
13	Gland Seal (4)	GP135
14	Gland Nut	GP136
15	Trigger	GP137
16	Trigger Pin	GP138
17	Jet Seal	GP139

# USING THE HOBBY PLUS SPRAY GUN

## SPRAY PATTERN

The shape of spray pattern can be determined by rotating the aircap into 3 positions. To select the spray pattern required, slightly slacken the aircap locking ring, turn the aircap to one of the positions shown below, then tighten the aircap locking ring - finger tight only.

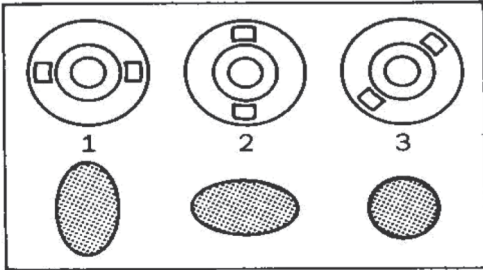

- 1 Use this position when spraying from side to side.
- 2 Use this position when spraying up and down.
- 3 Use this position when spraying small items, corners or angles.

## PAIN T FLOW

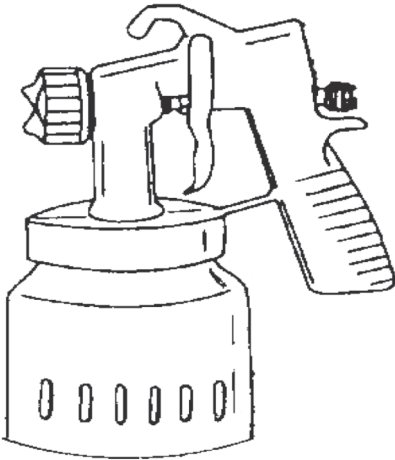

Paint flow adjusting screw.

The amount of paint being applied is adjusted with the paint flow adjusting screw. Turn in to decrease the flow and turn out to increase the flow.

# USING THE ANB300 SPRAY GUN

## SPRAY PATTERN / SHAPE ADJUSTMENT

The shape of spray pattern can be determined in three ways, turn the air cap to one of the positions shown below, you may need to loosen the air cap retaining ring first.

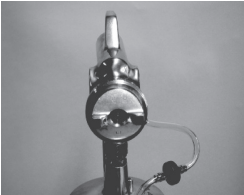

For spraying side to side.



For spraying up and down.



Use the control knob to change from the fan to spot pattern quarter turn only required.

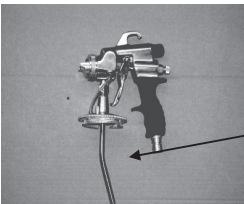

When spraying upwards (ceilings) turn the cup top 180° so that the paint tube faces towards the handle.

## PAIN T FLOW ADJUSTMENT

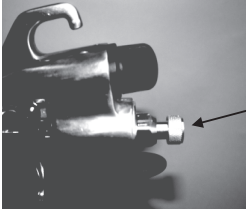

Turn the paint flow adjusting screw in to decrease the flow and screw out to increase the flow.

**Hint !** It is better to spray two light coats rather than one heavy coat, this will reduce the risk of runs or sagging forming.

## AIR HOSE CONNECTION

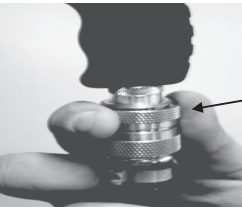

The air hose is fitted with a quick release connector, pull back the collar of the connector then push on to the base of the spray gun handle, at the same time release the collar. To remove, pull back the collar and the connector will come away from the spray gun.

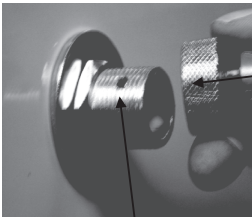

To connect the air hose to the turbine, screw the hose connector onto the outlet of the turbine making sure the thread is not crossed.

It is normal for this hole to exhaust air when the machine is in use.



## SELECTING A SPRAY SET UP

The ANB300 Spray gun is factory fitted with a 1.3mm Needle, Jet and Air Cap set.

Part No	Size	Material
ANB329	0.8mm	Lacquers, Wood Stains, Synthetics, Cellulose, Acrylics, Oil, Fine intricate output.
ANB330	1.3mm	Lacquers, Wood Stains, Synthetics, Cellulose, Acrylics, Oil, Polyurethanes, Glitter Paints, Fluorescents, Creosote, Wood Primer. Fine to Medium output.
ANB331	2.0mm	Polyurethanes, Glitter Paints, Fluorescents, Creosote, Wood Primer, Emulsions, Adhesives, Floor/Paving Paint, Medium to Heavy output.
ANB336	2.8mm	Hammers, Oil Base, Primers, Enamels, Marine, Masonry, Texture Coatings, Heavy Primers, Water and Solvent based Adhesives. Higher viscosity products.

## CLEANING THE GUN AFTER USE

Care must be taken in cleaning and maintaining your spray gun.

1. Empty any unused material from the paint cup and wash out any residue with the appropriate solvent.
2. Remove air cap, clean with solvent. Ensure the air holes in the cap are clear.
3. To clean the spray jet you will have to first remove the air cap.

Ensure all parts are clean before re-assembly.

Note:- Replace any worn or damaged seals.

## FAULT FINDINGS

### Paint leaking from the spray jet.

Needle not seating in the spray jet

Check for debris or worn parts

### Poor atomisation/splattering

Paint too thick

Check viscosity

Wrong spray set up

Refer to guide

### Paint leaking

From gland nut/seal

Check the tightness of the nut or replace seal

From cup

Check cup seal

# ANB300 SPRAY GUN

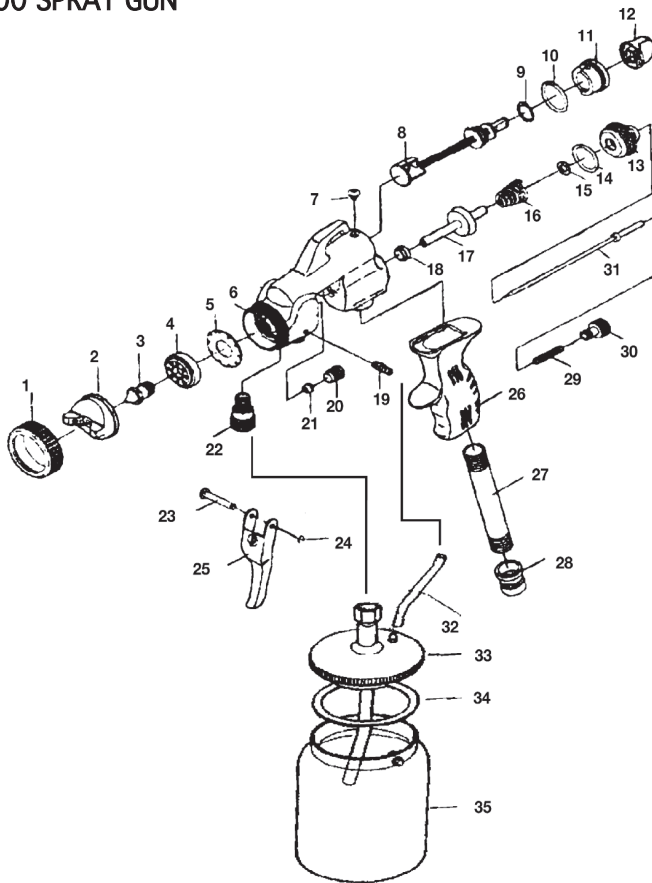

1	ANB301	Air Cap Retaining Ring	19	ANB317	Air Feed Connector
2	ANB330	Air Cap 1.3mm	20	ANB318	Gland Screw
3	ANB330	Spray Jet 1.3mm	21	ANB319	Gland
4	ANB302	Air Distributor	22	ANB320	Fluid Stem
5	ANB303	Air Distributor Gasket	23	ANB321	Trigger Pivot
6	ANB304	Spray Gun Body	24	ANB322	Circlip
7	ANB305	Set Pin	25	ANB323	Trigger
8	ANB306	Air Flow Control Stem	26	ANB324	Handle
9	ANB307	O Ring	27	ANB325	Air Tube
10	ANB308	O Ring	28	ANB326	Connector
11	ANB309	Control Valve	29	ANB327	Needle Spring
12	ANB310	Control Knob	30	ANB328	Paint Flow Adjusting Screw
13	ANB311	Paint Flow Adjusting Body	31	ANB330	Needle 1.3mm
14	ANB312	O Ring	32	ANB332	Air Feed Pipe
15	ANB313	Seal	33	ANB333	Cup Top
16	ANB314	Valve Spring	34	ANB334	Cup Top Seal
17	ANB315	Air Valve	35	ANB335	Paint Cup
18	ANB316	Valve Seal			

# PAINT VISCOSITY

The correct viscosity of the material is essential to ensure an optimum finish. Most materials will require thinning before use.

To achieve the correct viscosity you need to use the viscosity cup supplied. Hold your finger over the small hole on the base of the cup, fill the cup with the material to be sprayed. Take away your finger and time the material until it ceases to be a steady flow and starts to drip.

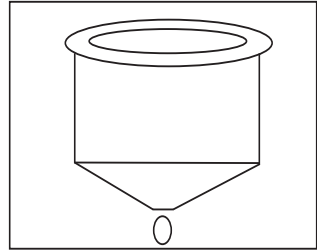

The following chart may be helpful.

VISCOSITY CHART	
Type of product	Approximate time
Cellulose	18 seconds
Creosote	As supplied
Emulsion	27 seconds
Hammer	24 seconds
Gloss Enamel	24 seconds
Polyurethane (Household. 1 pack )	24 seconds
Polyurethane ( Industrial. 2 pack )	As Instructed
Wood Stain	As supplied
Adhesives	17 seconds
Gel Coats	18 seconds

# SPRAYING TECHNIQUES

Before commencing to spray it is advisable to spray on to a sheet of card or suitable material to ensure the spray pattern and viscosity are correct.

Hold the spray gun approximately 150 to 200mm from the work to be sprayed. If the spray gun is held too close to the work piece then excessive material will be deposited, If it is held too far away then a dry spray is caused giving a rough sandy finish to the work.

At the beginning of each stroke trigger the spray gun on and at the end of each stroke trigger off, this will avoid a build up of material at the beginning and ends of each stroke. The speed of stroke should be constant. Move the spray gun parallel to the work surface, tilting the spray gun up or down or in a curve will give an uneven coat.

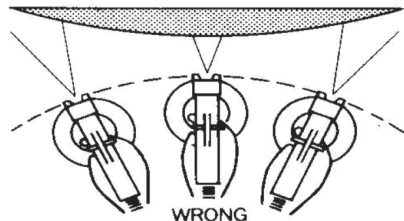
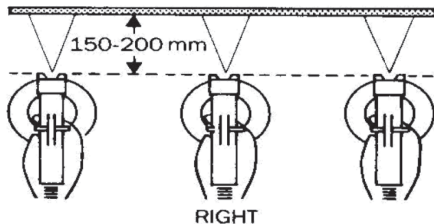

## SPRAYING LARGE SURFACES

Adjust the paint flow to increase the flow of material, spray in sections only overlap each stroke by approximately 30%.

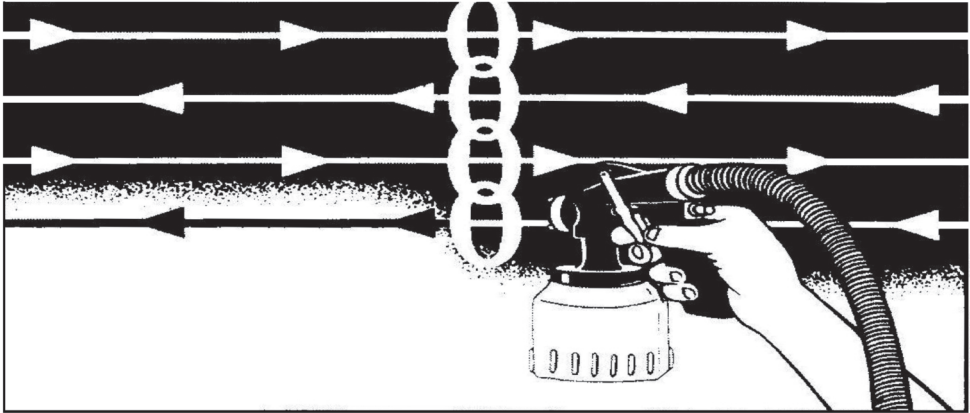

## SPRAYING CORNERS

Adjust the spray pattern to the spot, decrease the material flow and spray both surfaces at the same time.

Always spray the edges and corners before the main work.

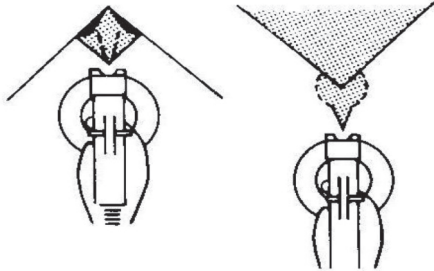

## SPRAYING CYLINDERS

For small diameter cylinders up to 30cm spray vertically, for larger cylinders spray around the cylinder in sections as you would on large surfaces.

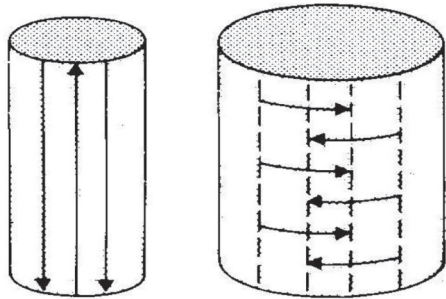

## FILTER REMOVAL / REPLACEMENT

**IMPORTANT NOTES:- ALWAYS TURN THE TURBINE OFF AND REMOVE THE MAINS PLUG BEFORE CARRYING OUT ANY SERVICE WORK.**

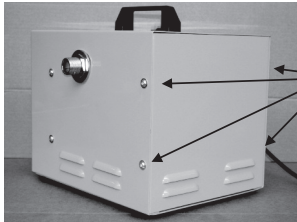

Remove all 4 fixings

Remove 2 fixings / washers

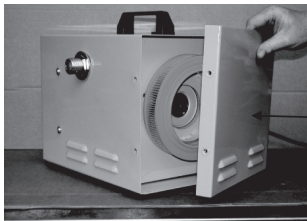
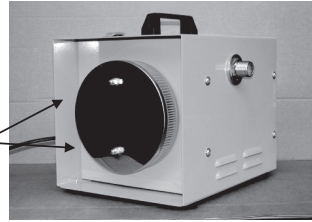

Remove filter plates from both sides of the turbine

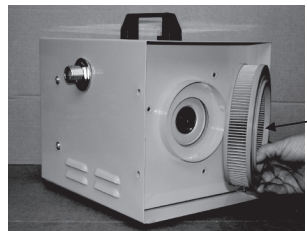
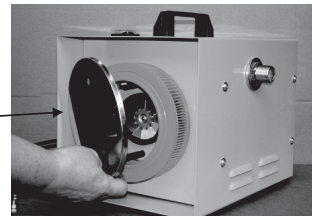

Remove both filter elements

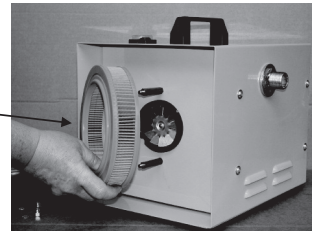

**Replace the filter elements and re-assemble in reverse order.**

The part number for the filter element is APT622. Remember these should be replaced every 6 months or sooner in dusty environments.





## FAULT FINDING

### Sags or runs:

Too much material  
Spray gun moved too slowly  
Material too thin  
Spray overlapped too much

Screw in the paint flow adjuster  
Move the spray gun faster  
Check viscosity  
Only overlap by 30%

### Dusty Appearance:

Not enough material  
Spray gun too far away from work  
Surface not prepared

Unscrew paint flow adjuster  
Hold spray gun 150 - 200mm from work  
Prepare surface, ensure dust free

## PREVENTATIVE MAINTENANCE

Your Apollo turbine requires minimal maintenance, check the turbine filters every time you use the turbine, replace the filters every 6 months or sooner in dusty environments.

The turbine bearings are sealed and lubricated for life. There is no maintenance or adjustment required.

Replace all spray gun gaskets and seals at regular intervals to prevent leakages.

**If you require any further assistance please call your local dealer or:-**

**Bambi Air Compressors Ltd**  
152 Thimble Mill Lane  
Heartlands  
Birmingham  
B7 5HT  
United Kingdom

**Tel: 44 (0) 121 322 2299**

**Fax: 44 (0) 121 322 2297**

**E. Mail: [sales@bambi-air.co.uk](mailto:sales@bambi-air.co.uk)**